



Model NBFV2-2A

Integrated heating, cooling, and ventilation system for variable speed furnaces, with or without air conditioners (1½ to 5 tons), serving one or two zones

NightBreeze^â

Gas Furnace INSTALLATION INSTRUCTIONS

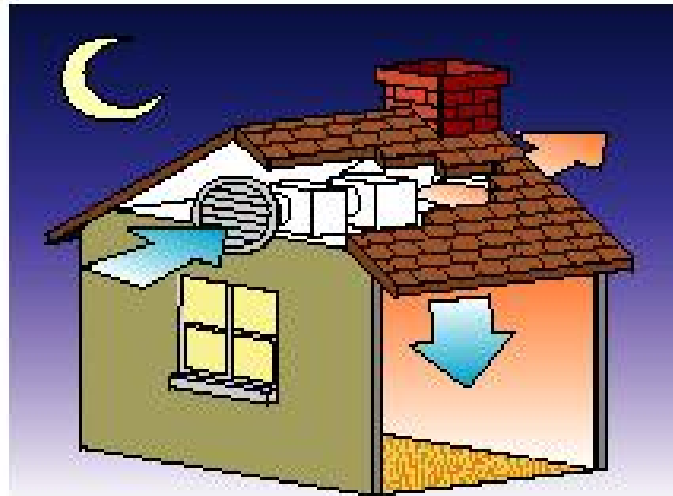

TABLE OF CONTENTS

Product Description	2	Installation	9
General	2	Preparation & Scheduling.....	9
Vent Damper.....	2	Vent Damper Installation	10
Overview of Controls.....	2	Control Wiring	11
Control Specifications.....	3	Control Wiring Steps.....	12
Description of Operation.....	3	Wiring Verification	13
Diagnostics	5	Control Setup	13
Equipment Placement & Sizing	5	Startup	17
Damper and Furnace Location	5	Troubleshooting	18
Outside Air Intake Location.....	6		
Duct and Register Sizing	6		
Vent Damper Dimensions & Clearances.....	8		
Vent Damper Placement	8		
Zone Dampers	8		
Systems Requiring Multiple Returns.....	8		
Cooling Coil and Condenser Sizing	9		
Return/Relief Air.....	9		
Placement of Control Components	9		

IMPORTANT NOTES TO INSTALLER

- Review these instructions thoroughly prior to beginning installation.
- Installation of the NightBreeze system must conform to local building, mechanical, and plumbing codes.
- Before attempting to perform any service or maintenance, turn the electrical power to unit off at the disconnect switch.
- Provide these instructions to the owner for future reference.

PRODUCT DESCRIPTION

General

The key value offered by NightBreeze systems is their ability to use outdoor air for natural ventilation cooling, while seamlessly integrating heating, air conditioning, and ventilation cooling control functions. The NightBreeze Model NBFV2 is a residential control system that combines with certain variable speed furnaces and condensing units to provide both summer ventilation cooling and year-round fresh air ventilation, as well as heating and air conditioning. The NBFV2 also provides up to two zones of temperature control. The system offers exceptional indoor comfort, air quality, and energy savings.

Model NBFV2 components include a controller, thermostats (one per zone), outdoor temperature sensor, leaving air temperature sensor, outside air vent damper, fan motor wiring harness, and optional zone dampers. NBFV2 controls are only compatible with specific furnaces that are powered by G.E. ECM motors (see approved list).

Vent Damper

The vent damper is a single-blade motor-actuated 4-way damper that typically mounts in the attic above the return air grille. In normal heating or air conditioning mode the damper delivers return air to the furnace. In ventilation mode (for ventilation cooling or fresh air) the damper delivers outside to the furnace and vents indoor to the attic through the return grille. The damper includes a filter slot for filtering both return air and outside air.

Overview of Controls

The NBFV2 control module mounts to the side of the furnace and is connected to the zone thermostats, an outdoor temperature sensor, the vent damper, and zone dampers as applicable. The thermostat provides for scheduled heating and cooling operation using either simple or detailed schedule information (a setup option), as well as short-term temperature overrides. The thermostat also allows the homeowner to select the lowest temperature the house should be ventilated to in summer, and allows the exact amount of wintertime fresh air ventilation to be selected. All settings are preserved during power losses. Consult this manual for control setup and the Owner's Manual for additional information on control operation.

To facilitate variable speed control of the blower motor for operation of ventilation cooling and fresh air ventilation, the NBFV2 control bypasses the furnace controls to directly control the ECM motor. This is accomplished by inserting an intermediate wiring harness between the low voltage connector to the motor and the furnace wiring harness. This intermediate harness is provided as part of the control package, and is installed by the field technician.

Control Specifications

Heating Stages: 2

Cooling Stages: 2

Number of Schedule Periods: 4 heating, 4 cooling, 1 pre-cool

Maximum Number of Zones: 2

Thermostat Wiring: 4 conductor (digital)

Description of Operation

NightBreeze controls allow three basic operating modes: *Off*, *Cooling*, and *Heating*. These are selected using the Mode button. *Pre-cooling* and *Vacation* modes are also accessible using the Menu button. Ventilation cooling will only occur in *Cooling* and *Vacation* modes, and fresh air ventilation is enabled only in *Heating* mode. Control modes are described below.

Off Mode: This mode is used to turn the system off and to allow for setting the clock, selecting *Vacation* mode, providing for air conditioner pre-cooling (to take advantage of time-of-use utility rates), resetting the filter change notification, and accessing Advanced and Technician settings.

Cooling Mode: In cooling mode the control maintains air conditioning setpoints in accordance with the entered schedules. If the cooling schedule is set to “Simple”, only a single cooling setpoint is allowed, otherwise, a detailed schedule will be applied. In addition to setting a maximum desired indoor temperature (or schedule) the user can set a minimum desired indoor temperature to prevent over-cooling.

As the outdoor air temperature falls below the indoor temperature, the vent damper opens and the fan circulates outdoor air into the house. Indoor air is relieved through the damper into the attic. The ventilation airflow rate is automatically determined by the controller, and increases as days become warmer. During the hottest weather the airflow rate increases to the maximum CFM set in Technician Settings (0.6 CFM/ft² is recommended). The vent damper will also open while the air conditioner is running to provide “economizer” cooling if outdoor air is cooler than indoor air.

The minimum indoor temperature at which ventilation cooling is allowed is also automatically varied with weather conditions to prevent over-cooling. On hotter days the ventilation system attempts to achieve a lower indoor air temperature than on mild days.

To help the user understand the consequences of cooling temperature settings a graphical display is provided that shows both the high (maximum) and low (minimum) temperature settings, as well as a prediction of what the range of indoor temperatures will be on the next day. This prediction is based on user settings and current weather patterns, and is computed using a two-day history of outdoor and indoor temperatures and is updated each day at midnight. The temperature predictions are also used to control fan speed during ventilation cooling operation, and to set the actual low limit for ventilation cooling.

The predicted indoor temperature range is displayed as a shaded “comfort bar” shown in Figure 1 and is accessed by pressing “Set” in cooling mode. If the comfort bar remains below the high setting, or air conditioner setpoint, it is unlikely that the air conditioner will run the next

day. Depending on Advanced Settings, either a simple weekend-weekday schedule can be entered, or detailed times and temperatures can be entered using a graphical display. If the cooling schedule is set to “Simple” in Advanced Settings, the high temperature can be set from the display shown in Figure 1. If the cooling schedule is set to “Detailed” in Advanced Settings, the high temperature displayed will be consistent with whatever scheduled temperature is in effect.

Figure 1: Low and High Limit Temperature Settings and “Comfort Bar”

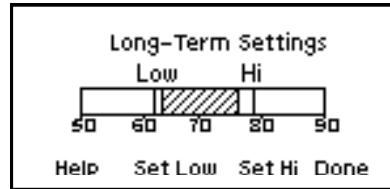

Pre-Cooling Mode: If the local utility provides a time-of-use rate option, significant utility bill savings can be realized by using the air conditioner to pre-cool the house prior to the utility’s on-peak rate period. Cooling stored in the mass of the house can decrease or eliminate afternoon air conditioner operation during “on-peak” periods when utility rates are the highest. The ventilation low limit temperature is used as the base temperature for pre-cooling, and the offset from this base can be modified in Technician Settings. For example, if the control calculates that the ventilation cooling system should cool the house to 68°F but it only cools to 74°F and the pre-cooling offset temperature is 3°F, the air conditioner will cool the house to 71°F during the hours scheduled (e.g. 8 AM –12 PM). This optional mode is described further in the Control Setup section.

Heating Mode: Operation in heating mode is no different than for standard furnaces, except that the system has the capability to provide fresh air ventilation using the vent damper. Depending on Advanced Settings, either a simple weekend-weekday temperature schedule can be entered, or detailed times and temperatures can be entered using a graphical display.

Vacation Mode: If Vacation mode is selected the system maintains indoor temperatures in a range between the low and high temperature settings entered, and all other temperature schedules are ignored. In this mode cooling is provided by outside air ventilation when it is cooler outdoors than indoors, and by the air conditioner when it is not. If the indoor temperature falls below the low setting the furnace operates to keep the temperature above this setting.

Fresh Air Ventilation: The system is capable of supplying fresh outdoor air to the house in heating mode by opening the damper and running the fan at its lowest speed. The rate of fresh air ventilation (in average CFM per hour) can be set or disabled in Technician Settings.

When enabled, the fresh air system operates as follows: If during any given hour the thermostat calls for heating, the damper will immediately open to admit outside air, which is heated by the furnace and supplied to the house. The damper will remain open long enough to deliver the volume of air selected in Technician Settings. If there is no call for heat during a given hour, at the end of the hour the damper will open and the fan will run at its lowest speed for sufficient time to deliver the desired volume of air. If the outdoor temperature falls below the Minimum Fresh Air Temperature set in Technician Settings, the system will stop providing fresh air. Fresh air ventilation can be turned off by setting *Ventilation Rate* to 0 in Technician Settings.

Conflicts Between Zone Thermostats: Operating modes are set by the user, and there is no automatic heating/cooling changeover (except in vacation mode). If the mode is changed on the thermostat in one zone, the thermostat in the other zone automatically changes to the same mode. For example, if both are in heating mode and one is switched to cooling, then the other also switches to cooling and whatever temperature schedules have been entered are applied.

Diagnositics

The NBFV control includes several diagnostic features designed to assure proper maintenance and to identify system failures. These are accessed through the diagnostics menu.

Filter Change: If the total fan operating hours since the last filter reset exceeds the Filter Interval in *Technician Settings* then the Service LED will be lit on all thermostat screens and “Replace Filter” will be displayed on the *Diagnostic Screen*. This will be reset when the user has entered the *Filter Reset* screen and reset the fan operating hour counter.

Service Interval: Service Interval is set using *Technician Settings*. If the Service Interval is greater than zero and Last Service Date + Service Interval > Current Date, then the Service LED will be lit on all WDU screens and “Schedule Service” will be displayed on the *Diagnostic Screen*. This will be reset when the technician enters a new Last Service Date.

Vent Damper Diagnostics: If either supplemental fresh air ventilation or ventilation cooling is operative, the temperature difference between the leaving air sensor and the outdoor sensor will be measured. If this difference exceeds 10°F for longer than 15 minutes, the Service LED will be lit on all WDU screens for as long as the mode is operative, and “Vent damper delta T out of range” will be displayed on the *Diagnostic Screen*. The ‘error’ condition will reset when the technician enters a new Last Service Date.

System Diagnostics: If the Leaving Air Temperature (LAT) measured by a sensor installed in the supply plenum remains above 65°F for longer than 5 minutes with the compressor on, or remains below 80°F for longer than 5 minutes with the heating system on, then the Service LED will be lit on all WDU screens for as long as the system is on and “Leaving air temp out of range” will be displayed on the *Diagnostic Screen*. The ‘error’ condition will reset when the technician enters a new Last Service Date.

EQUIPMENT PLACEMENT & SIZING

Vent Damper and Furnace Locations and Duct Requirements

The furnace must be installed according to the furnace installation manual, and should be reasonably close to the vent damper to minimize pressure and thermal losses. The vent damper mounts directly over the ceiling return air grille, which must be located in an accessible location since access to the damper is required for filter replacement. Refer to *Dimensions and Clearances* for damper space and clearance requirements. Because the NightBreeze system uses a single return, “jumper ducts” between the area where the return air grille is installed and other major rooms are required. These will also improve the effectiveness of ventilation cooling.

If multiple return air grilles are installed the outside ventilation air will be diluted by return air, diminishing the ventilation cooling effectiveness. Refer to page 8 for alternative ducting approaches to avoid this problem.

Outside Air Intake Location

Outside air must be ducted from an intake location to the damper as shown in Figure 2. Use either a gable-mounted louver, a dormer vent, or false chimney with suitable vent cap for the outside air intake. Refer to Table 5 for required free area.

Duct and Register Sizing

The recommended airflow rate for ventilation cooling is 0.6 CFM per ft² of floor area. Ducts should be sized using the ACCA Manual J airflow rate or 0.6 CFM per ft², whichever is greater. Recommended minimum sizes for outside air and return duct mains are indicated in Table 1. Size branch ducts and registers by apportioning the recommended ventilation rate from the table according to room or zone load, and using a maximum external static pressure of 0.3" w.c.

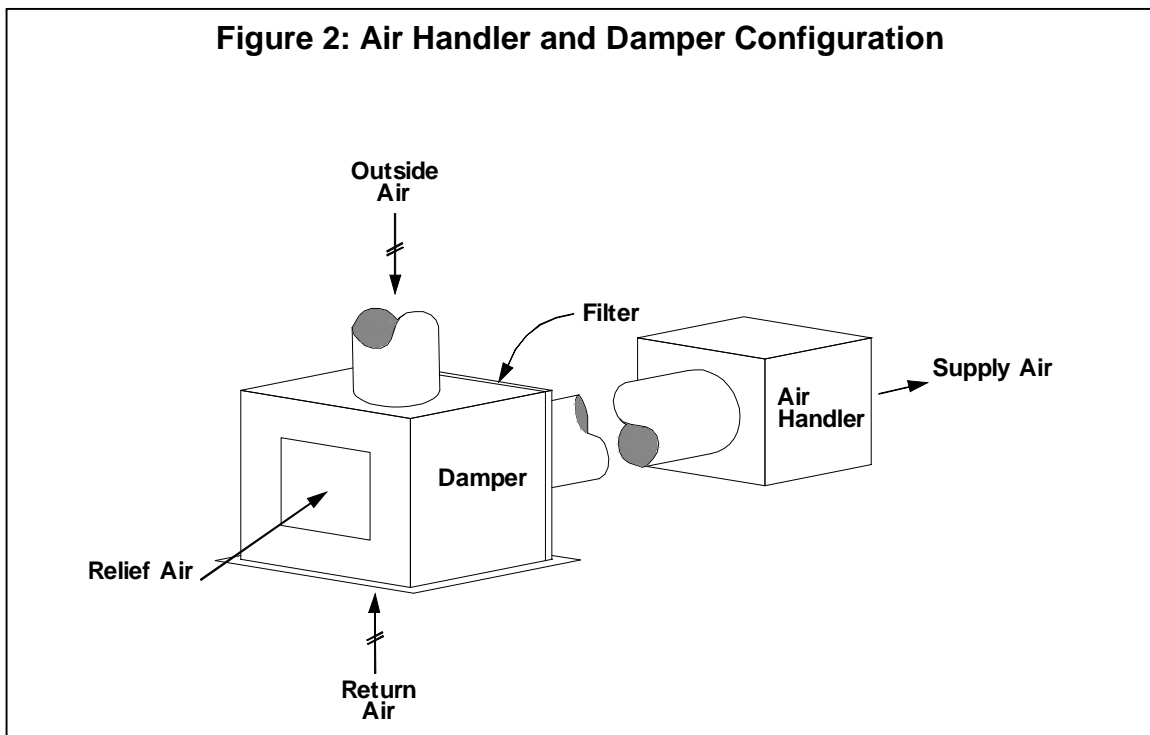
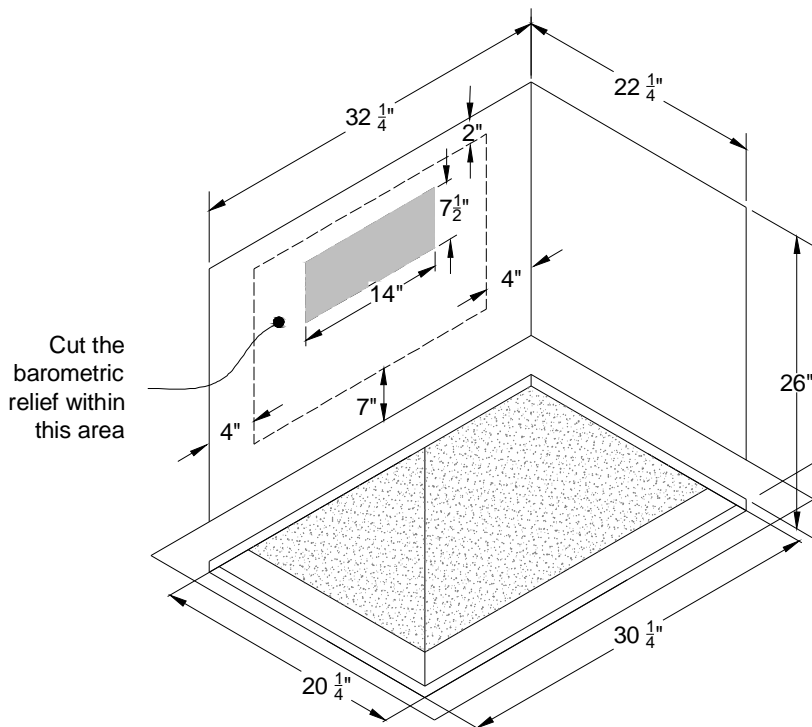
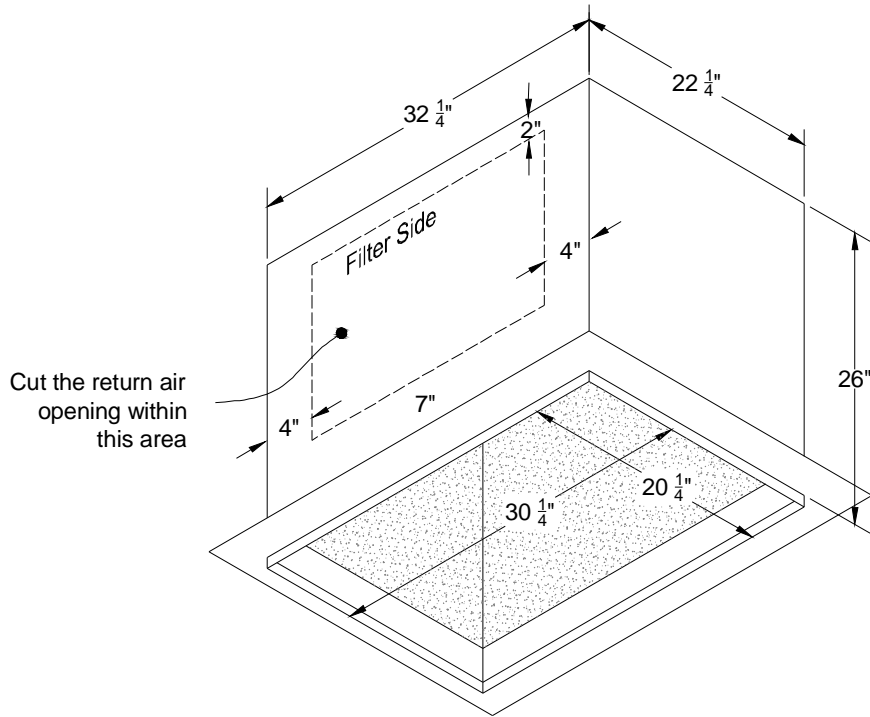

Table 1 DUCT SIZING RECOMMENDATIONS			
House Floor Area	Recommended Maximum Ventilation Airflow	Minimum Duct Size	Vent Intake Minimum Free Area, ft ²
Up to 1400 ft ²	800 CFM	14"	1.00
1400 - 1800 ft ²	1000 CFM	16"	1.25
1800 - 2200 ft ²	1300 CFM	18"	1.63
2200 - 2600 ft ²	1600 CFM	20"	2.00
2600 - 3000 ft ²	1800 CFM	20"	2.25

Vent Damper Dimensions and Clearances

Dimensions for the vent damper are shown in Figure 3. Zero clearance is permitted to all damper surfaces, except a 12" clearance must be provided adjacent to the barometric relief.

Figure 3: Vent Damper Dimensions



Vent Damper Placement

The vent damper must be located in the attic, central to supply air registers, and immediately above the 20" x 30" hinged return air grille. The installer must provide a duct connection between the damper and an outside air intake (typically a gable or dormer vent), as well as a return duct connection to the furnace.

The damper requires two duct connections, one to the air handler and one to the outside air intake. If the damper is not installed in a space that is vented to outdoors, a relief duct will also be required (see Figure 2). The barometric relief damper must be kept clear of insulation and obstructions.

Zone Dampers

The NBFV2 control may be used with single or two-zone systems. If a second thermostat is connected to the NBFV2 controller, the system will automatically detect the second zone. No changes are necessary in the Advanced or Technician Settings menus.

Systems Requiring Multiple Return Air Ducts/Grilles

It is good practice to provide separate return air to large rooms such as master bedrooms to prevent pressure imbalances between rooms when doors are closed. However, if returns are installed as shown in Figure 4 without a damper, outside air is diluted while the system is in ventilation cooling mode, significantly reducing the cooling effectiveness. There are three alternatives to eliminating this problem, represented by Figures 4, 5, and 6. The solution shown in Figure 4 is preferred because it provides better air distribution and does not make filter changing more difficult (as in Figure 6).

Figure 4: Motor Driven Return Air Damper in Secondary Return

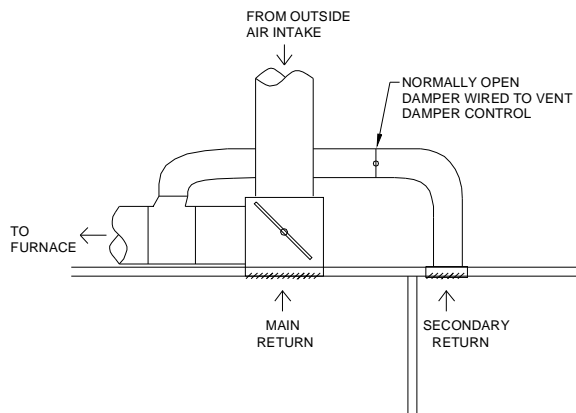

Figure 5: Jumper Duct

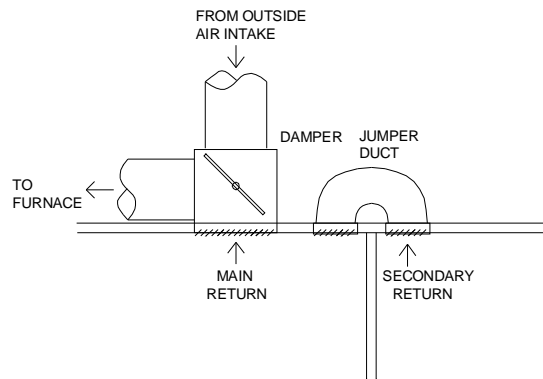
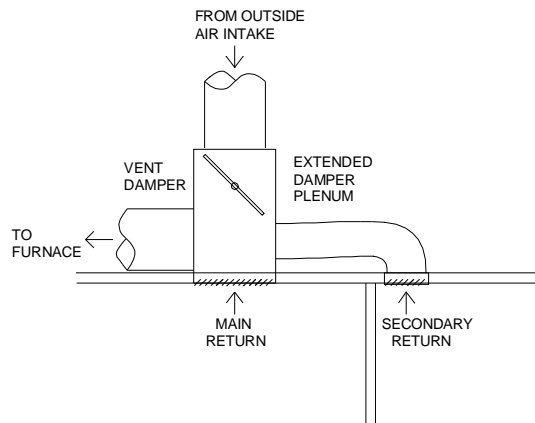

Figure 6: Extended Plenum Damper Box



Cooling Coil and Condenser Sizing

Air conditioners should be sized in accordance with ACCA Manuals J and S. Depending upon climate, house design, and control settings, NightBreeze will reduce the cooling load under design conditions, thereby providing an extra safety margin on air conditioner sizing.

To minimize pressure drop and excessive fan energy use during ventilation cooling, it is recommended that the cooling coil be oversized in accordance with Table 2. The larger coil will also improve air conditioner performance. Refer to condenser manufacturer's instructions for proper refrigerant line sizing.

Table 2 COOLING COIL SIZING	
Condenser Size	Recommended Minimum Cooling Coil Size
2 tons	3½ ton
3 tons	4 ton
3½ - 5 tons	5 ton

Return/Relief Air

To assure ventilation cooling performance as well as performance of heating and cooling systems, transfer ducts or grilles must be installed to provide return/relief air to any spaces that can be isolated from the return air grille by closed doors. This may apply to any space with more than 100 CFM of supply air (undercut doors can usually supply up to 100 CFM).

Placement of Control Components

Controller: Mount the controller on the side of the furnace in a location that provides ready access to wiring connections. Wiring connections will be made between the controller and the furnace, thermostat(s), outdoor temperature sensor, supply air sensor, vent damper, and zone dampers (if used).

Thermostat: Locate the thermostat(s) on an interior wall, near the return air grille. For two story residences with a single zone, install the thermostat on the second floor.

Outdoor Temperature Sensor: Proper placement of the outdoor temperature sensor is very important to assure proper control operation and temperature readings. Always locate it on the north side of the building where it will be shaded from direct sunlight. Avoid placement above a roof or adjacent to a west or northwest facing wall, or anywhere where hot air might collect. If two NightBreeze systems are installed, always position the outdoor sensors in the same location. There is only one outdoor temperature sensor per NightBreeze regardless of the number of zones.

Supply Air Sensor: Select a location on the supply plenum that is most likely to have mixed air, and drill a hole for the sensor and mount it securely to the supply plenum.

INSTALLATION

Preparation and Scheduling

Prior to Rough-In

1. Select and coordinate mounting locations for the furnace and vent damper (refer to the furnace installation manual for details pertaining to furnace installation).
2. Select and coordinate the location of the outside air intake and outside air duct routing.

3. Complete duct sizing using ACCA Manual D or other recognized methods.

Rough-In

1. Mount the controller to the furnace and install the motor wiring harness and the supply air sensor.
2. Install the vent damper box and ducting to the furnace and outside air source. Note that the vent damper assembly should be removed from the damper box and safely stored during construction to prevent it from being damaged during dry walling and painting.
3. Install wiring between the controller and the furnace thermostat connections and the fan motor harness (provided with the NBFV2). Also complete wiring between the controller and the vent damper box, supply sensor, thermostat(s), outdoor air sensor, and zone dampers (if applicable).

Finish

1. Install the vent damper into the damper box and connect wiring to the damper motor.
2. Install and connect thermostat(s), outdoor temperature sensor, and supply air temperature sensor.
3. Install a filter grille over the vent damper intake and install the air filter in the damper box.
4. Verify all wiring connections and test the system.

Vent Damper Installation

An exploded view of the vent damper is provided in Figure 7. The damper mounts immediately above the return air grille with the flanged side down. Up to 18" round or 20" oval openings may be cut for duct connections (see Fig. 3 for locations. Refer to Table 1 for sizing outside air ducting; the duct connecting the damper to the furnace must be the same size.

The side of the damper opposite the barometric relief opening connects to the furnace. The top opening connects to the outside air intake. Note that the damper has only one correct installed position. The damper mechanism should be removed from its duct board enclosure and stored in a safe place to avoid damage during construction. Provide a 20" x 30" hinged filter grille for access to the filter, which mounts in a vertical slot inside the damper. Do not install the filter grille until the damper mechanism is permanently installed in the duct board box. The filter grille flange must be notched to allow the filter to slide in and out freely. The damper accommodates a 20" x 30" x 1" filter. 3M Filtrete® 1000 or 1250 filters, or equivalent are recommended. Do not install a filter over the top of the filter grille – use only the filter slot provided.

VERY IMPORTANT

Do not move damper blade manually as this will damage the damper actuator. The installer shall be responsible for any damage to this component.

Figure 7: Exploded View of Damper

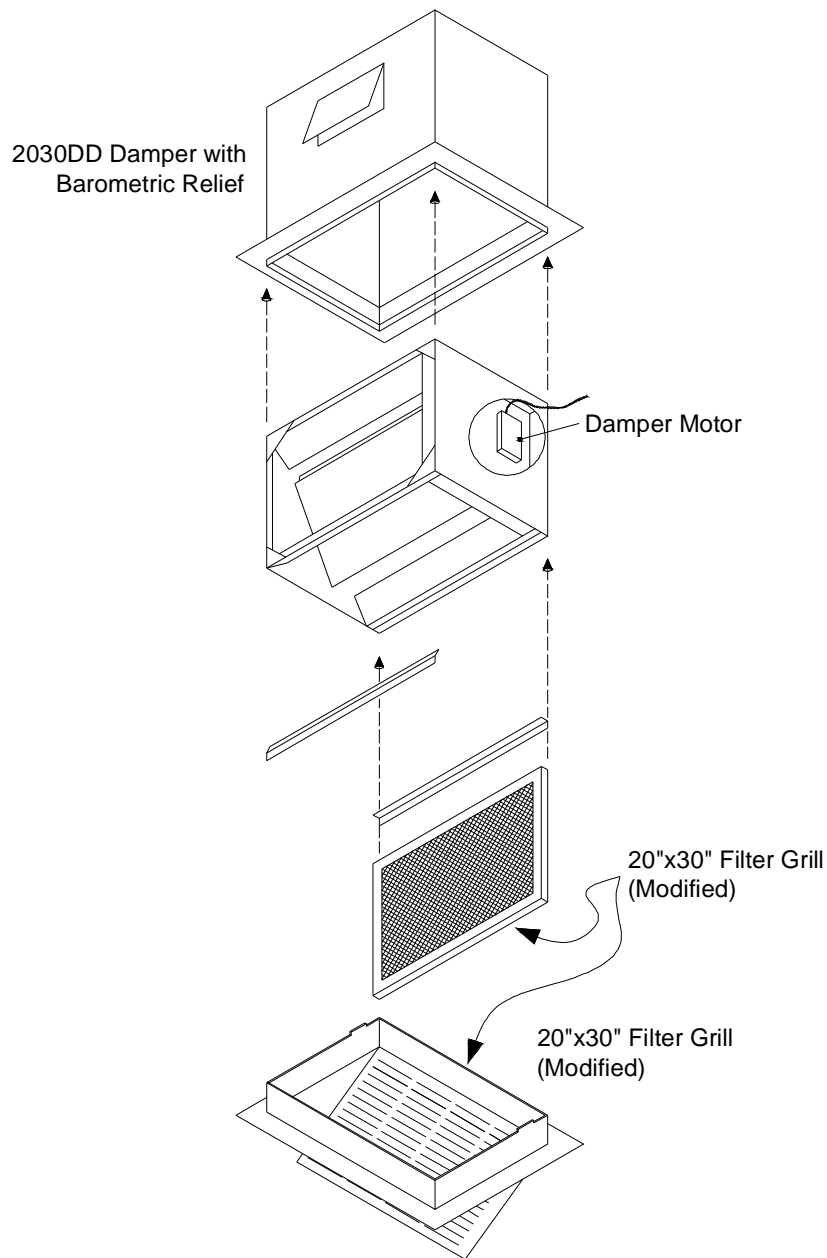

Control Wiring

IMPORTANT – High Voltage Wiring

All wiring shall be in accordance with local and national electrical codes.

The blower motor is continuously powered. Allow 5 minutes after disconnecting power for capacitors to discharge before servicing the motor.

IMPORTANT – Low Voltage Power Supply

Do not connect two transformers to the NBFV2 controller. See instructions below for selecting which transformer to use (furnace transformer or an external transformer). Failure to heed these instructions may damage to the furnace controls.

IMPORTANT – Low Voltage Wiring

Thermostats utilize digital communications. Use only the thermostat provided with the system (TS40NBF). **Do not** attempt to operate the system by jumpering control terminals, and **do not** connect controls to an external low voltage power source.

Control Wiring Steps

Refer to Figure 8 for an overview of field wiring and complete connections as follows:

1. Mount the NBFV2 controller to the side of the furnace, leaving the wiring terminals accessible.
2. Unplug the 16 pin low voltage connector from the ECM fan motor, and insert the wiring harness provided with the NBFV2 controller, plugging the end with the long black and white leads into the fan motor and the other end into the connector that was removed from the motor.
3. Connect the white wire from the motor harness provided to the C2 terminal of the control board, and the black wire to the PWM terminal.
4. Follow instructions below for powering the NBFV2 controller:
 - a. If the system does not use zone dampers (single zone) and the furnace transformer is 40VA or larger, you may power the NBFV2 controller from the furnace transformer by connecting the B (24V common) and R terminals at the furnace to the 24C and RW/RC connections marked "POWER" on the controller. In this case the jumper above the "POWER" marking must be in place, and the 2A fuse must be installed in the upper socket marked "HVAC".
 - b. If the system does include zone dampers (two-zone), the controller must be powered by an external 40VA transformer. To avoid risking damage to the furnace controls it is essential that the jumper above the "POWER" marking be removed, and that the fuse be plugged into the lower socket marked "EXT".
5. Complete the rest of the wiring between the furnace R, W, Y, and G terminals and corresponding terminals on the controller. If a single stage furnace and/or air conditioner are used, wire to the W1 and/or Y1 terminals of the NBFV2 controller (not W2 or Y2). If two-stage equipment is used install wiring between all W and Y terminals as shown in Figure 8.
6. Connect thermostat (WDU) wiring as indicated in Table 3 and Figure 8. (Ground and +12V wires from the thermostats share terminals on the controller.)
7. Connect vent damper wiring as indicated in Table 4 and Figure 8.
8. Connect zone damper wiring (if applicable) as shown in Figure 8. (24VAC common wires from all dampers share the fused 24C terminal on the controller.)
9. Install and connect the outdoor temperature sensor and supply air temperature sensor as shown in Figure 8. Do not run outdoor temperature wires in the same conduit as high voltage wiring as this may cause erroneous temperature readings.

10. Connect wiring between the furnace and the condensing unit per the furnace manufacturer's instructions. (No connections to the NBFV2 board are necessary.)

Wiring Verification

To verify correct wiring connections follow the steps listed in the *Startup* section.

Table 3 THERMOSTAT WIRING		
Thermostat (Terminals labeled "CU")	Connecting Wire Color	Control Board at Furnace (Terminals labeled "ZONE X WDU")
-	Green	Gnd*
+	Red	+12*
C	Black or Blue	C
D	White	D

*If two thermostats are used they must share the Ground and +12 terminals.

Table 4 VENT DAMPER WIRING		
Damper (wire color)	Connecting Wire Color	Controller Terminals (Labeled "VENT DAMP")
White (3)	White	NO
Green (2)	Green	NC
Red (1)*	Red	24C

*Zone dampers, if used, must share the 24C terminal.

CONTROL SETUP

IMPORTANT!

Airflow rates and other permanent control settings must be completed before turning the system over to the owner.

Control settings fall into three categories: *Normal Settings*, *Advanced Settings*, and *Technician Settings*. *Normal Settings* are for everyday use and include operating mode, temperatures, and schedules. These settings are easily accessed using the Mode and Set buttons and are described in the Owners Manual.

Advanced Settings, listed and described in Table 5, are less frequently used user settings and are accessed through the Menu button (in "Off" mode). The installer should set the clock and may assist the owner with selection of the types of schedules to be used. These settings are described in the Owners Manual.

Technician Settings are settings that must be modified at the time of installation, and are listed in Table 6. To access the Technician Settings menu, do the following:

1. Press the *Mode* button on the thermostat until *Off* is displayed.
2. Press the Menu button and select *Advanced Settings* from the menu using the up and down arrows and the "Select" button.
3. From the Advanced Settings menu, hold down the "+" and "-" buttons below the display simultaneously until the *Technician Settings* menu appears.

Use the up/down arrow buttons to select the menu item and the - / + buttons to adjust the settings. Each setting is explained in Table 6. When finished, press the button marked *Done*.

Figure 8: Wiring Diagram

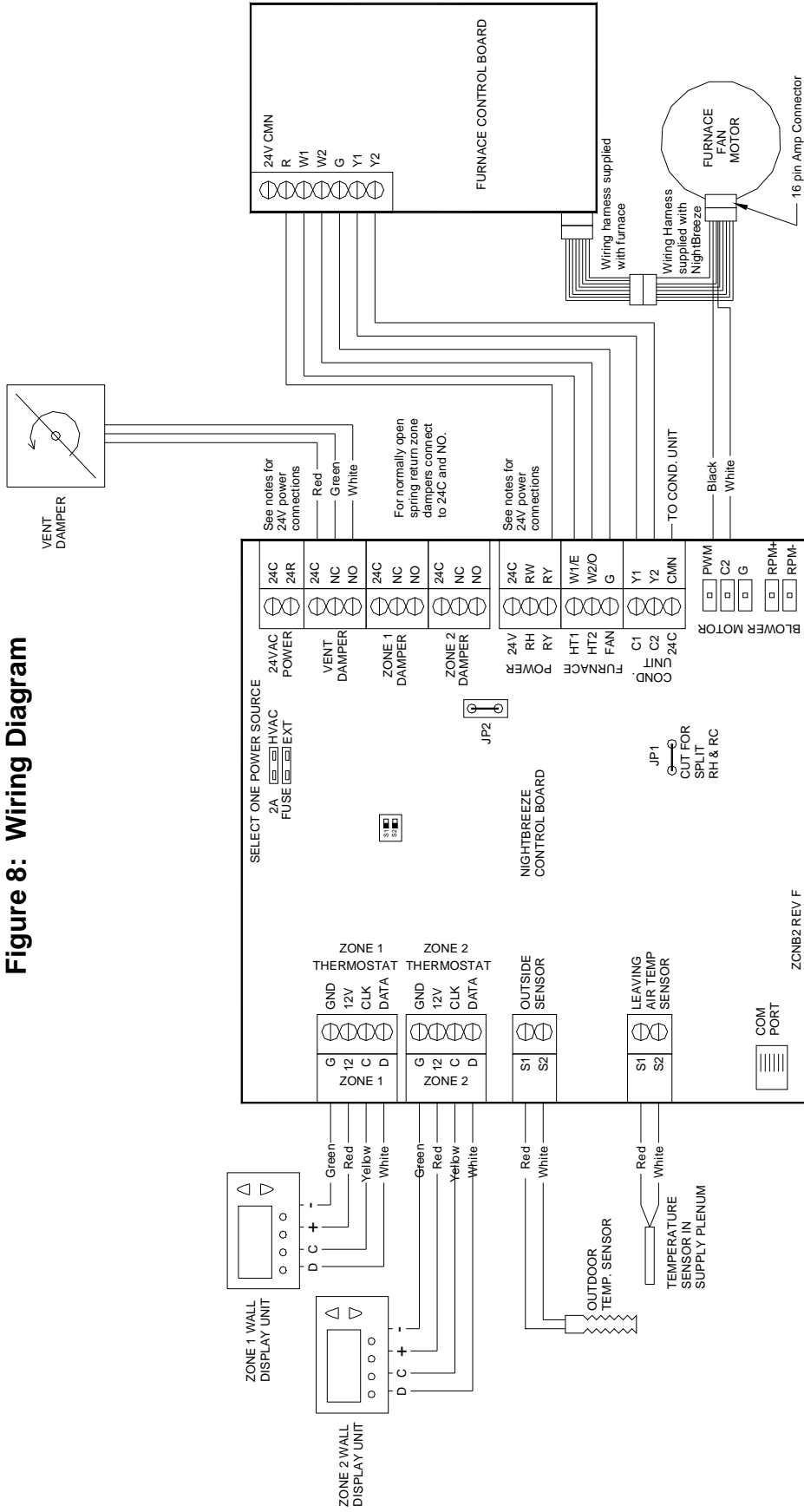

NOTES

- IF INSTALLING ZONE DAMPERS:**
1. Install an external 40VA transformer and connect to "External 24VAC Input" to power the dampers and control board.
 2. Move fuse to lower (EXT) position.
 3. Remove or cut jumper at JP2.
 3. Do not connect between the POWER 24C and the furnace 24V common.
- IF NOT INSTALLING ZONE DAMPERS:**
1. Move fuse to upper (HVAC) position
 2. Insure jumper JP2 is in place.
 3. Connect from the control board POWER 24C and RC/RH to the furnace 24V common and 24V R.
- REFER TO INSTALLATION INSTRUCTIONS FOR PLACEMENT OF OUTDOOR TEMPERATURE SENSOR.

**Table 5
ADVANCED USER SETTINGS**

Menu Item	Description	Default	Range
Pre-Cooling	Run A/C pre-cooling routine?	No	Yes, No
Start Hour	Hour of day pre-cooling starts	6 am	4 am to 10 am
Stop Hour	Hour of day pre-cooling stops	12 pm	8 am to 12 pm
Screen Time-out	Idle seconds before screen reverts to home screen	30	0 to 90 by 10s
Back Light Time-out	Idle seconds before back light turns off	30	0 to 90 by 10s
Heating Schedule	Heating schedule type	Simple	Simple, Detailed
Cooling Schedule	Cooling schedule type	Simple	Simple, Detailed
Synchronize Zones	Synchronize zone schedules	Yes	Yes, No
Man Fan Time	Length of time fan will run when the <i>Fan</i> button is pressed, hours	1	0 to 4

Note that not all settings in Table 6 may be visible. For example, if furnace stages = 1 then “Heat Second Stage CFM” will not be displayed.

IMPORTANT!

Critical settings in Table 6 that must be made by the installer are highlighted and marked with a ‘*’. Default values are typically acceptable for all other settings.

**Table 6
TECHNICIAN SETTINGS**

Menu Item	Description	Default	Setting Range
System Type	Type of heating system (furnace or air handler)	Furnace	Furnace, AH ¹
Max CFM*	Maximum furnace CFM (at highest tap setting, from furnace specifications)	2200	0 to 3000 by 100s
Furnace Stages*	Furnace heating stages	1	1,2
AC Installed*	Air conditioner status	Yes	Yes, No
AC Stages*	Condensing unit speeds or stages	1	1,2
AC on Delay	Time delay between condensing unit cycles, minutes.	5	0 to 9
Vent Delta Temp	Indoor-outdoor temperature difference at which ventilation cooling will be initiated, °F.	5	0 to 9
Vent Fan CFM*	Maximum airflow for ventilation cooling, CFM (0.6 CFM per ft ² of conditioned floor area is recommended)	2000	100 to Max CFM by 100s
Man Fan CFM	Maximum airflow for manual fan operation, CFM.	1500	100 to Max CFM by 100s
Heat First Stage CFM* (or Heat Fan CFM if one stage furnace)	Airflow rate for furnace first stage (from furnace specifications).	600 ²	100 to Max CFM by 100s
Heat Second Stage CFM*	Airflow rate for furnace second stage (from furnace specifications)	1200	100 to Max CFM by 100s

¹ Refer to the NightBreeze air handler installation manual for settings used with air handlers.

² This value is used to calculate the fresh air ventilation rate during cooling, not to set the heating fan speed.

Table 6 (continued)
TECHNICIAN SETTINGS

Menu Item	Description	Default	Setting Range
Ventilation Rate*	Average hourly airflow rate for heating mode fresh air ventilation, CFM.	50	0 to 95 by 5's
Heating Pickup	Pickup time after setback, minutes.	30	0 to 60 by 5's
Inter Stage Temp	Differential at which to switch stages, if Furnace Stages = 2 or AC Stages = 2	3	1 to 5
Max First Stage Run Time	Maximum first stage run time, minutes, if Furnace Stages = 2 or AC Stages = 2	10	0 to 20
Min First Stage Run Time	Minimum first stage run time, minutes, if Furnace Stages = 2 or AC Stages = 2	5	0 to 20
Comfort Adjust	Preferred comfort range, °F.	0	-5 to +5
Pre-Cool Offset	Delta T between vent target temperature and pre-cooling setpoint	3	0 to 5
Tout Offset	Outdoor temperature sensor calibration, °F.	0	-9 to +9
Tin Offset	Indoor temperature sensor calibration, °F.	0	-9 to +9
Minimum Fresh Air Temp	Minimum outdoor temperature at which fresh air ventilation is allowed, °F.	50	35 to 70 by 5s
Filter Interval	Time between filter replacements, hours.	500	0 to 1000 by 100s
Service Interval	Time between service calls, months.	12	0 to 36
Last Service Date*	Date of last HVAC service	00/00/00	Date

The control uses 'Max CFM' and 'Vent Fan CFM' to establish the ventilation cooling airflow rate. Similarly, the control uses 'Heat CFM' to determine the length of time the vent damper should be opened to provide fresh air ventilation. Heating mode airflow settings must correspond to the furnace tap settings; refer to furnace specifications for this information. If these settings are not correct the system will not deliver the correct air volumes in ventilation cooling and fresh air ventilation modes. Table 7 provides recommendations for setting the Ventilation Rate.

Table 7
RECOMMENDED VENTILATION RATE SETTINGS

House Size (ft ²)	Vent Fan CFM	Manual Fan CFM	Heating Ventilation Rate
Up to 1400	800	600	15 CFM / bedroom + 15 CFM
1400 – 1800	1000	800	15 CFM / bedroom + 15 CFM
1800 – 2200	1300	1000	15 CFM / bedroom + 15 CFM
2200 – 2600	1600	1200	15 CFM / bedroom + 15 CFM
2600 – 3000	1800	1400	15 CFM / bedroom + 15 CFM

Setting the Clock: If the thermostat clock does not display the correct time, select *Off* mode and press the *Menu* button then select *Clock* from the menu. Use the ← and → buttons to position the cursor under the time or date digits you want to change, and use the up/down buttons to the right of the display to change the setting.

Temperature Settings: Refer to the Owner's Manual for information on changing temperature settings, and/or use the *Help* button.

Note: If the outside temperature displays 00, disconnect and restore power to the air handler. This will occur if the thermostat is removed from its wall plate and replaced without first cutting power.

Sensor Calibrations: Temperature sensors used by both the indoor thermostat and for sensing outdoor temperature may be calibrated using advanced control settings. Ideally this is done at the time of installation. To calibrate the sensors use an accurate handheld digital thermometer to measure air temperature in close proximity to the thermostat and the outdoor temperature sensor. If the measured temperature is lower than the temperature displayed by the thermostat, enter a negative offset, and vice versa. For example, if the thermostat reads 70° indoor temperature and the measured temperature is 72°, enter a +2 next to *Tin Offset*. Be sure to allow adequate time for the handheld thermometer to equilibrate to ambient temperatures before taking readings.

STARTUP

1. Apply power to the furnace.
2. Verify that the thermostat display is lighted.
3. Follow instructions in **CONTROL SETUP** for configuring control settings.
4. Verify that the gas supply to the furnace is turned on.
5. At the thermostat select *Heat* mode and press the *Up* button until the set temperature exceeds the indoor temperature by 2°.
6. The Fan and Heat indicator lights should light, and the fan and furnace should start. If a two-stage furnace is installed, raise the temperature setting to 4° below the indoor temperature, wait 5 minutes, and verify that the furnace is operating in second stage.
7. If air conditioning is installed, verify condenser operation by selecting *Cool* mode and activate cooling by pressing the *Down* button until the set temperature is 2° lower than the indoor temperature.
8. The Fan and A/C lights should light. Verify that the condenser is operating. If a two-speed condenser is installed, lower the temperature setting to 4° below the indoor temperature, wait 5 minutes, and verify that the furnace is operating in second stage.
9. Verify damper operation by pressing the *Fan* button (from either *Heat* or *Cool* mode) twice. The squiggly arrow will indicate that the system is bringing in outdoor air (a circular arrow indicates that air is being recirculated). The *Fan* light should light. Open the hinged filter grille and visually inspect the damper to insure that it changes position to admit outdoor air.
10. Refer to **TROUBLESHOOTING** if the system fails to operate properly.

TROUBLESHOOTING

<p>Powerup Test No display on thermostat</p>	<ul style="list-style-type: none"> • Verify power at furnace • Verify 24VAC at R & C connections to control board • Verify power LED on control board is lighted • Check thermostat control wiring 	<ul style="list-style-type: none"> • Restore power to furnace • If all items check out and display does not appear, replace thermostat
<p>Heating Mode Test Furnace fails to start in either stage</p> <p>Furnace tries to start but blower fails to run</p>	<ul style="list-style-type: none"> • Verify that appropriate heating stage LED (W1 or W2) is lighted on control board • Verify that motor wiring harness is properly installed • Remove wiring harness, restore factory motor connections, and retest 	<ul style="list-style-type: none"> • If LED is on, check W1/W2 wiring between control board & furnace • If LED is off replace control board • Review instructions and reinstall wiring harness • If motor operates, replace wiring harness. If motor does not operate, contact furnace manufacturer for warranty service
<p>Cooling Mode Test Condensing unit fails to start</p> <p>Condenser runs but furnace blower does not</p>	<ul style="list-style-type: none"> • Verify that condensing unit is powered • Verify that appropriate condenser speed LED (Y1 or Y2) is lighted on control board • Verify that motor wiring harness is properly installed • Remove wiring harness, restore factory motor connections, and retest 	<ul style="list-style-type: none"> • Restore power as needed • If LED is on, check Y1/Y2 wiring between control board & furnace and control wiring from furnace to condenser • Review instructions and reinstall wiring harness • If motor operates, replace wiring harness. If motor does not operate, contact furnace manufacturer for warranty service
<p>Vent Damper Test Damper fails to operate when fan button is pressed twice</p> <p>Damper operates in reverse (brings in outdoor air when in normal heating or cooling mode but not when Fan button is pressed twice)</p>	<ul style="list-style-type: none"> • Verify that vent damper LED on control board is lighted • Verify damper wiring – damper motor should be receiving 24V across Red and White wires • Check damper wiring: red = common, white = open (to outside), green = closed (normal return air position) 	<ul style="list-style-type: none"> • Correct wiring connections • If damper motor is receiving power, replace damper motor. The motor is easily damaged if the damper blade is forced. • White and green wires are reversed; switch them either at the damper or the control board